

MANUAL ON HARMFUL MARINE MICROALGAE

Edited by

G.M. Hallegraeff
Department of Plant Science, University of Tasmania
Australia

D.M. Anderson
Woods Hole Oceanographic Institution, Woods Hole
United States of America

A.D. Cembella
National Research Council, Nova Scotia
Canada

Technical Editor

H.O. Enevoldsen
IOC Science and Communication Centre on Harmful Algae
Denmark

The designations employed and the presentation of the material in this publication do not imply the expression of any opinion whatsoever on the part of the Secretariats of UNESCO and IOC concerning the legal status of any country or territory, or its authorities, or concerning the delimitations of the frontiers of any country or territory.

For bibliographic purposes, this document should be cited as follows:

Manual on Harmful Marine Microalgae
Hallegraeff, G.M., Anderson, D.M., Cembella, A.D. (Eds)
IOC Manuals and Guides No. 33. UNESCO 1995
(English only)

The preparation of this Manual was supported by the Danish Agency for International Development Aid (DANIDA) and the Danish Institute for Fisheries Research.

Published in 1995
by the United Nations Educational,
Scientific and Cultural Organization,
7, Place de Fontenoy, 75352 Paris 07 SP

Printed in UNESCO's Workshops

© UNESCO 1995
Printed in France

11. Cyst methodologies

D.M. Anderson, Y. Fukuyo and K. Matsuoka

Many marine phytoplankton species produce dormant cysts or resting spores during their life histories. Alternation between a dormant, benthic stage and a motile, vegetative existence is a complex process that must be considered in our efforts to understand and manage blooms of harmful algal species. Cyst germination provides an inoculum for many blooms, and cyst formation can subsequently remove substantial numbers of cells in later stages. Such cells have other important ecological roles with respect to species dispersal, survival through adverse conditions, and genetic recombination when sexuality is involved in their formation (Wall, 1971). Among the toxic or harmful marine phytoplankton species are many that use this life history strategy. Some of these are listed in Table 11.1, though it should be recognized that many unlisted (non-toxic) species can cause harm due to dense biomass accumulation and anoxia. Here we present a compilation of methodologies useful in laboratory and field studies of phytoplankton resting cysts and spores. Methods for dinoflagellate cysts will dominate the presentation, since most cyst-forming species belong to this group and it has therefore been studied most thoroughly. Information relevant to other algal classes will also be presented when appropriate.

GENERAL CONCEPTS, DEFINITIONS

Cysts

Most toxic or harmful species reproduce by asexual, binary division. Under certain conditions, however, sexuality is induced, involving a series of developmental events that produce morphologically and physiologically distinct cell types called gametes, zygotes, and hypnozygotes (reviewed in Pfister and Anderson, 1987). The term "cyst" is used to describe a non-motile cell which lacks flagella and an ability to swim. Dinoflagellates form two different types of cysts - temporary cysts and resting cysts (Fig. 11.1). In this manual, the term "cyst" will refer to "resting cyst" or hypnozygote. The terms "germination" and "excystment" will be used synonymously, as will "cyst formation" and "encystment".

Temporary cyst

This non-motile cell is formed when motile, vegetative cells are exposed to unfavorable conditions such as mechanical shock or a sudden change of temperature or salinity. They are typically round or oval-shaped protoplasts liberated by thecal rupture (ecdysis). Initially, cell contents are the same as those of vegetative cells, but through time, starch grains become apparent and pigments break down and change their cellular distribution (Anderson, 1980). Temporary cysts are frequently observed in laboratory cultures, especially in stationary growth phase. They are occasionally observed in natural plankton samples, although it is always difficult to ascertain whether the cysts were present naturally, or were formed by the stresses of the sampling. When conditions become favorable again, temporary cysts quickly re-establish a vegetative, motile existence. The dormancy interval thus allows them to withstand short-term environmental fluctuations. All planktonic species can have a temporary cyst stage, and for most, this stage is unrelated to the reproductive process. However, some species such as

Alexandrium hiranoi and *Peridinium quinquecorne* use this stage for asexual reproduction (i.e. they can complete asexual cell division only through the formation of temporary cysts).

Resting cyst

This thick-walled, highly-resistant stage is occasionally formed in cultures and routinely occurs in natural plankton populations, often towards the end of a bloom (Anderson *et al.*, 1983; Lewis *et al.*, 1979). Resting cyst formation (Fig. 11.1) begins with the sexual fusion of gametes, which produce a swimming zygote (planozygote) that remains in the plankton for several days before falling to the sediment as a non-motile cyst (termed a hypnozygote). Under favorable conditions, cysts can remain viable in sediments for 5-10 years, sometimes even longer.

Dormancy vs. quiescence

It is important to use dormancy terminology with care. The literature on seeds of higher plants defines "dormancy" as the suspension of growth by active endogenous inhibition, and "quiescence" as the suspension of growth by unfavorable environmental (i.e. exogenous) conditions. Thus dormant cysts cannot germinate, even under optimal environmental conditions, while quiescent cysts are competent to germinate, but are inhibited from doing so by some environmental factor. Most cysts must proceed through a mandatory resting period (lasting weeks to months, depending on species) before they are capable of germination. This interval is generally considered a time for physiological "maturation" (Pfiester and Anderson, 1987). The length of this mandatory interval varies considerably among species (12 hrs to 6 months; Pfiester, 1977; Anderson, 1980), and for a single species, can vary with the storage temperature as well. Thus cysts of *A. tamarense* stored at 4°C mature in 4-6 months, whereas storage at warmer temperatures shortens the mandatory interval to 3 months or less (Anderson, 1980). The duration of this process can have a significant effect on the timing of recurrent blooms, as species with a long maturation requirement may only seed one or two blooms per year, whereas those that can germinate in less time may cycle repeatedly between the plankton and the benthos and contribute to multiple blooms in a single season. Recent study, however, suggests that some species such as *Gymnodinium catenatum* and *Pyrodinium bahamense* may not require this maturation period (Blackburn *et al.*, 1989). Once a cyst is mature and the dormancy interval is over, the resting state will continue if external conditions are unfavorable for growth. Thus a quiescent cyst cannot germinate until an applied external constraint (such as cold temperature) is removed. A further complication arises in species which can alternate between dormancy and quiescence through time, due to an endogenous annual "clock" which restricts germination to a particular time of the year (Anderson and Keafer, 1987). Mature, quiescent cysts of *A. tamarense* did not germinate in a consistent manner when exposed to optimal growth conditions throughout the year, but instead showed a variable response depending on the season. An endogenous annual clock was implicated, which might explain the germination of cysts deposited in deep waters where seasonal environmental cues such as temperature or daylength are small or nonexistent.

Factors controlling quiescence

The factors that initiate germination of mature cysts are not known for all species. The primary stimulus for excystment of temperate species is generally accepted to be a shift in temperature to favorable levels, as occurs in seasonal warming or cooling (Huber and Nipkow, 1922, 1923; Anderson and Wall, 1978; Anderson and Morel, 1979). Spontaneous germination of cysts without a change in temperature has been noted on several occasions, however (von Stosch, 1973; Pfiester, 1975, 1977; Binder and Anderson, 1987). Cysts stored at cold temperatures

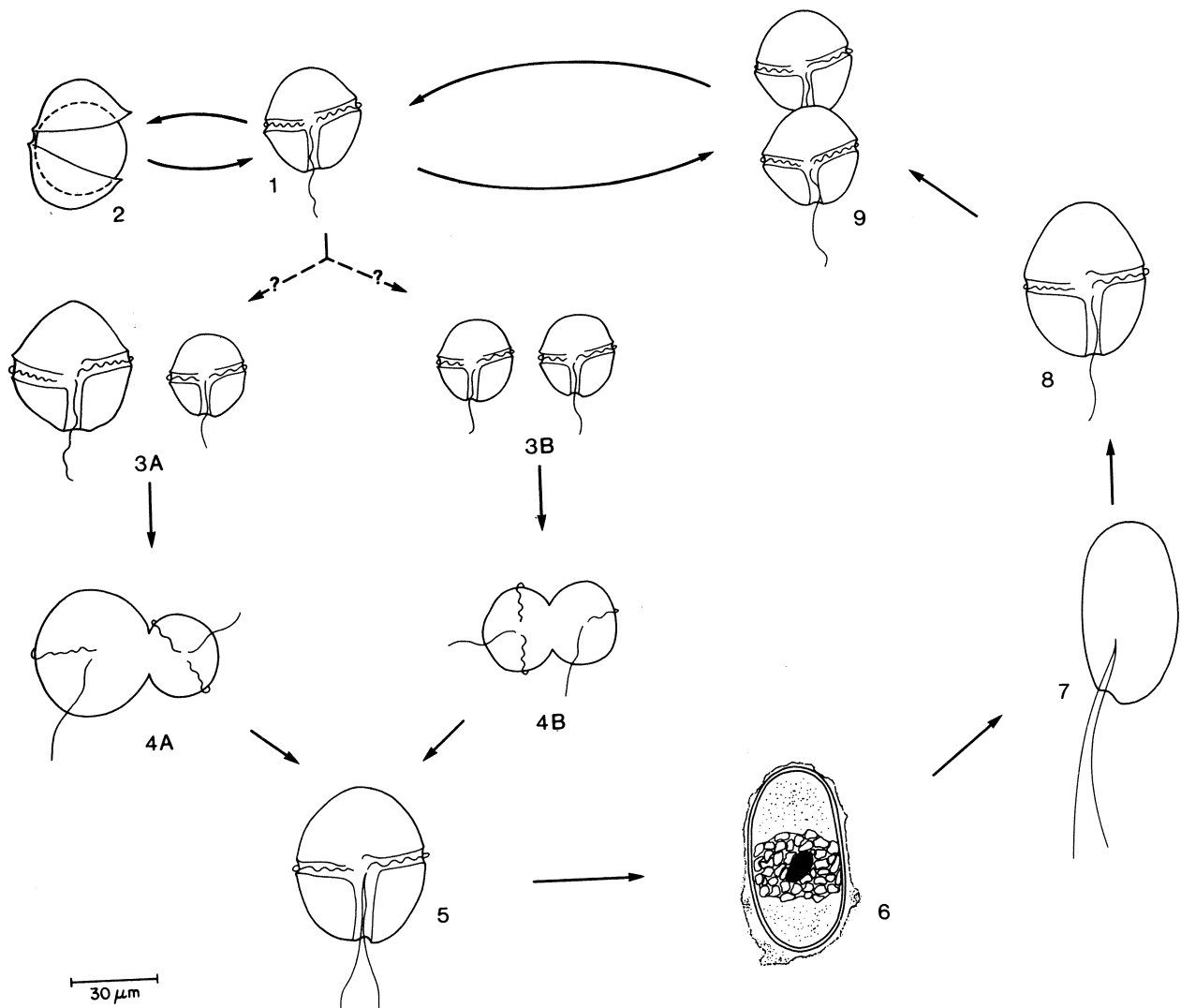

Figure 11.1. Life cycle diagram of a dinoflagellate, using *Alexandrium tamarense* as a model. Two different gamete formation strategies are shown for generality. Stages are identified as follows: (1) vegetative, motile cell; (2) temporary or pellicle cyst; (3A) anisogamous "female" and "male" gametes; (3B) isogamous gametes; (4A & 4B) fusing gametes; (5) swimming zygote or planozygote; (6) resting cyst or hypnozygote; (7&8) motile, germinated cell or planomeiocyte; and (9) pair of vegetative cells following division.

often remain quiescent until the temperature is increased (Huber and Nipkow, 1922; Anderson, 1980). A similar phenomenon has been observed for cysts of *A. tamarense* held at high temperatures, which maintained quiescence for a year and germinated only when temperatures decreased to a favorable level (Anderson and Morel, 1979; Anderson, 1980). This argues for the existence of a permissive temperature "window" within which quiescent cysts will germinate, but outside of which they will continue their resting state (Dale, 1983; Pfiester and Anderson, 1987). In general, temperature can maintain quiescence for extended periods, determine the duration of dormancy after cyst formation, synchronize or entrain cyst populations for more uniform germination, and initiate the excystment process (reviewed in Pfiester and Anderson, 1987). Temperature is thus very important in the dynamics of dormancy, quiescence and germination, though much of the research to date has focused on temperate species. Species from tropical waters where temperature fluctuations are less dramatic might not be as reliant on temperature cues, but this awaits further research.

The effects of other environmental factors on dormancy and excystment are less studied. Nutrient concentrations and other water chemistry variables are not thought to exert significant influence on germination in dinoflagellate cysts, although Binder and Anderson (1987) report that germination of *Scrippsiella trochoidea* cysts was significantly slower in unenriched medium compared to nutrient-replete medium. However, large numbers of cysts often remain in the sediments even though ambient temperatures are suitable for excystment and cell division (Anderson *et al.*, 1983). This is attributed to the burial of many cysts beneath the oxygenated surface layer of sediments. All species tested thus far (Anderson *et al.*, 1987) have an absolute requirement for oxygen during germination. Some species must be exposed to light for either brief (Binder and Anderson, 1986) or prolonged intervals (Anderson *et al.*, 1987) before excystment is possible. Cysts that are buried deep in the sediment can thus remain quiescent for years, their fate either being eventual death if anoxia persists, or germination should they be transported to the sediment surface or overlying water.

Cyst identification

More than 81 marine and 20 freshwater species of modern dinoflagellates are known to produce cysts (Matsuoka *et al.*, 1989a; unpub. data). Of these species, less than a dozen have been known to cause red tides or toxic episodes (Table 11.1). Some cysts are similar to their motile form, but many are completely dissimilar. The important features used in identification of cysts are the shape of the cyst body and ornaments, wall structure and color, and the type of archeopyle (excystment opening) through which the germinated cell emerges. The archeopyle is a very useful criterion for classification to the family and genus levels. It is not visible, however, before excystment, so it is not possible to use this characteristic for identification of living cysts. Furthermore, in comparison with the morphology of motile cells, cysts are usually relatively simple, mostly spherical in shape. As a result, identification of cysts based on a single morphological character is not always reliable, and other characters such as morphology of ornaments, wall structure, color, and paratabulation must be examined. Descriptions and photographs of the cysts of harmful algal species are found elsewhere in this volume. For further details, a diagram of archeopyle types and several keys based on cyst shape and archeopyle type can be found in Matsuoka *et al.* (1989a) and in Chapter 20 of this Manual.

FIELD STUDIES

CYST DISTRIBUTIONS (MAPPING)

Knowledge of the distribution and abundance of cysts can be very useful in ecological and monitoring studies. Historically, such studies have been used to define the geographic range or

bloom dynamics of a particular harmful species (e.g. Anderson *et al.*, 1982a,b; Imai *et al.*, 1991), to identify potential "seedbeds" for bloom initiation (Tyler *et al.*, 1982) or sites for monitoring (Anderson *et al.*, 1982b), or to study the dispersal of an organism from one region to another (e.g. Anderson *et al.*, 1982b; Imai *et al.*, 1991; Tyler *et al.*, 1982). In some cases, it is useful to assess only the presence or absence of a species in a sample, whereas in other situations, a quantitative estimate of the abundance of that species is needed. Clearly, the methods used for these two different determinations will differ. There is probably limited need for quantitative cyst surveys in the initial phases of most projects. Time and effort would be better directed towards large-scale surveys on a presence vs. absence basis rather than quantitative studies over a necessarily much smaller area. Once the baseline surveys are established, it might then be appropriate to monitor cyst population dynamics using quantitative methods.

Table 11.1 Toxic or harmful species producing a resting cyst

MARINE SPECIES	REFERENCE
Dinophyceae	
<i>Cochlodinium sp.</i>	Fukuyo (1982)
<i>Cochlodinium sp.</i>	Matsuoka (1985a, 1987)
<i>Gymnodinium catenatum</i>	Anderson, <i>et al.</i> (1988), Matsuoka (1987),
<i>Alexandrium catenella</i>	Yoshimatsu (1981)
<i>Alexandrium cohorticula</i>	Fukuyo <i>et al.</i> (1990)
<i>Alexandrium minutum</i>	Bolch <i>et al.</i> (1991)
<i>Alexandrium monilatum</i>	Walker et Steidinger (1979)
<i>Alexandrium tamarense</i> (= <i>A. excavatum</i>)	Dale (1977), Anderson and Wall (1978), Anderson and Wall (1978)
<i>Pyrodinium bahamense</i> var. <i>compressum</i>	Steidinger <i>et al.</i> (1980); Matsuoka <i>et al.</i> (1989b)
Raphidophyceae	
<i>Chattonella antiqua</i>	Imai and Itoh (1988)
<i>Chattonella marina</i>	Imai and Itoh (1988)
<i>Heterosigma carterae</i> (= <i>akashwo</i>)	Imai and Itakura (1991)

SAMPLE COLLECTION

Site Selection

Cysts, as non-motile cells, will settle from the water column and accumulate in areas where lighter sedimentary materials such as silt and clay predominate. High energy environments are characterized by coarse, sandy substrates, which generally have low cyst abundance due to the winnowing away of finer materials. The best sites for cyst collection are thus those where the sediment is muddy rather than sandy. Sediment maps that indicate silt and clay areas can be used to identify good collection sites, or bathymetric maps can be used to identify basins or other depressions where finer materials can accumulate. Protected harbors and embayments are more likely to accumulate cysts than open coastal areas with wave and wind exposure. It is important also to avoid areas exposed to the air at low tide. Living cysts can still be found in such sediments, but viability is better from sites that remain permanently submerged.

Presence vs. absence

The geographic distributions of the cysts of several species have been mapped using qualitative approaches. For example, the simple presence or absence of *A. tamarense* cysts was determined along the coast of southern New England, highlighting regions with the potential for PSP, including several that had no prior history of the problem (Anderson *et al.*, 1982b).

When the absolute abundance of a species is not needed, a variety of sampling methods can be employed to collect sediment and analyze it for the organism of interest. These include commercial coring devices and grab samplers, as well as other devices which can be modified for sediment collection. For example, an old plankton net can be lowered to the sediment surface and slowly dragged across the bottom to collect the surface sediment layer that is often very rich in cysts. In shallower waters, a hand-held, manual bilge pump connected to a garden hose with a flattened funnel taped to the open end can be used to "vacuum" the surface sediment layer into a container. Either of these two approaches can be used in shallow waters from small boats or even while wading. If a grab sampler is used, care must be taken that the surface layer is not lost during retrieval, as it contains cysts formed in the recent past. Deeper in the sediment, cysts might be years or even decades older.

Boats are not always necessary. Careful site selection may permit access from land with chest waders. This is one way to increase the number of stations sampled for a given period of time or for a fixed budget. Another useful non-quantitative sampler is an electric or battery-powered submersible pump that can be lowered to the bottom and used as a vacuum. Be aware that pebbles and debris can clog the pump. SCUBA divers are also useful, but this requires more personnel, is depth-limited, and takes more time.

Clearly there is no standard method for collection. In shallow areas where boats cannot be used, the bilge pump is probably the method of choice. In deeper areas, a plankton net or grab sampler should be used when there is no winch, or when possible, collect several gravity cores and combine surface sediments (i.e. the top few cm that can be swirled and poured off easily).

Relative Abundance Surveys

Another survey approach is to count all cysts in a given sample, with each species then reported as a percentage of the total number. With this approach, it is not necessary to standardize the volume of sediment analyzed in each sample, so sampling and processing methods are considerably simpler than the quantitative approach described below. This method will give a good indication of where potential cyst beds are, especially if the sediments being sampled are fairly consistent with respect to cyst deposition dynamics. For comparisons among vastly different depositional sites over long distances of coastline, relative abundance can provide a useful measure of the relative importance of individual species in the plankton.

Quantitative surveys

Comprehensive, quantitative surveys have been conducted for *Alexandrium* species in the Gulf of Maine (Anderson and Keafer, 1985), the Bay of Fundy (White and Lewis, 1982), and the lower St. Lawrence estuary (Turgeon *et al.*, 1990; Cembella *et al.*, 1988). Other distributional studies include those for *Gyrodinium uncatenum* (Tyler *et al.*, 1982), *Gonyaulax polyedra* (Lewis *et al.*, 1979), and *Chattonella* (Imai and Itoh, 1988). The distribution and abundance of cysts have been shown to correlate with bathymetric features (e.g. basins), with the fine clay and silt sediment fractions, and with the transport pathways of major current systems (Anderson and Keafer, 1985; Cembella *et al.*, 1988).

Collection methods for studies in which the absolute number and distribution of cysts are to be determined place restrictions on the type of sampling to be conducted. The samples must be intact and undisturbed, and this typically calls for gravity or box corers. Some grab

samplers can obtain samples without loss of the surface layer, but this requires special precautions and should be verified before quantitative studies are initiated. Simple gravity corers can be manufactured at low cost, such as the one in Fig. 11.2 developed by the Tokyo University Fisheries Oceanography Laboratory. Some workers prefer to use corers with larger tube diameters than the TUFOL design (e.g. 5 cm rather than 2.2 cm). At the other extreme, a hydraulically damped Craib corer (Baxter *et al.*, 1981) obtains excellent samples (Anderson and

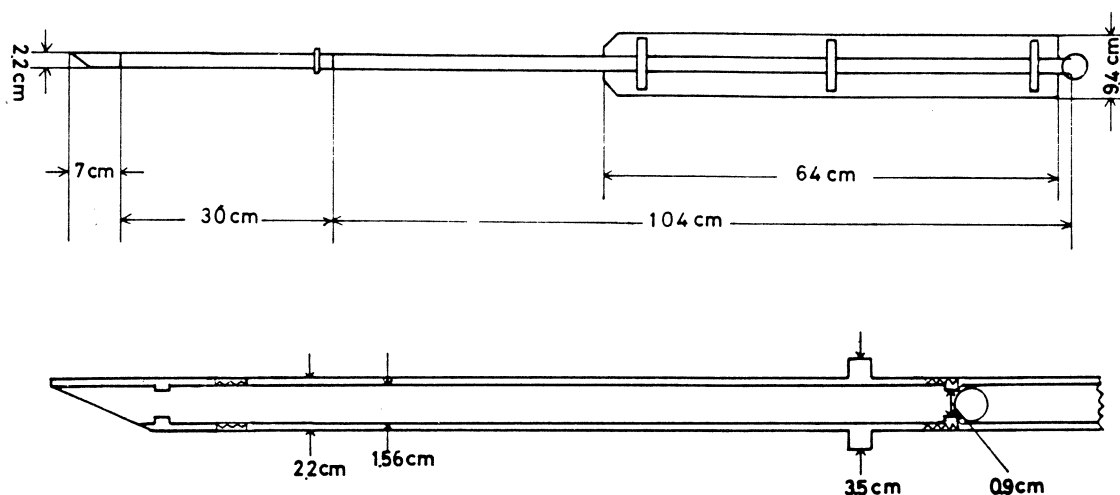

Figure 11.2. Simple gravity coring device designed by the Tokyo University Fisheries Oceanography Laboratory.

Keafer, 1985), but is quite expensive and can only be deployed from larger vessels. Box corers obtain large (0.1 m^2) samples that can be subsampled on deck by manually inserting small core tubes, but again the device is expensive and very heavy, and thus is restricted to larger vessels.

Once core samples are obtained, they should be capped (filled with water above the sediment), and stored in the dark and cold before processing. For temperate species at least, these precautions will minimize germination and bioturbation artifacts, and allow sample processing to be delayed until the samples can be returned to the laboratory.

Fixation

Since it is often possible to store living cysts for years in the laboratory, fixation is not commonly employed. In addition, fixation often alters the appearance of the cyst contents, removing one of the diagnostic criteria that are useful in their identification. Nevertheless, long-term records of cysts are useful, and preservation is therefore needed. Buffered formalin is often used for this purpose. Formalin (37% formaldehyde) saturated with carbonate or borate is added to sediment samples to a final concentration of 5-10%. If the sample is subsequently sieved and processed as described below, additional formalin is needed, though at a lower concentration (2-3%).

Storage

Resting cysts are highly resistant cells that can survive burial in sediments and sometimes ingestion by animals. Cyst longevity, which probably depends most critically on temperature and oxygen, varies considerably between species, but can be at least 5-10 years in natural marine sediments (Keafer *et al.*, 1992). Freshwater species are known to have survived for 17 years in lake sediments (Huber and Nipkow, 1922, 1923). Optimal survival appears to be associated with temperatures that are cold relative to the growth requirements of a particular species. For temperate species, storage at 2-4°C is desired. Storage of tropical species is problematic, as it is not yet clear how well they survive low temperatures. Refrigeration at 4°C may be harmful to tropical forms, so the best approach is probably to maintain the ambient temperature and to rely on anoxia to retard germination in stored samples. Storage of sediment samples in tightly-sealed containers quickly results in anoxic conditions due to organism respiration and the chemical oxygen demand of the sediments. Anoxia is effective in maintaining quiescence without excessive mortality (Anderson *et al.*, 1987). If the sample is not sealed and is instead left open to the atmosphere, oxygenation of surface sediments can lead to germination of cysts in upper sediment layers.

SAMPLE PROCESSING

Two basic procedures are used to process sediment samples for dinoflagellate cysts. One used predominantly for living cysts involves sieving (and sometimes sonication), but no harsh chemicals. This was originally described by Wall and Dale (1968). The other is a chemically rigorous palynological technique which leaves only cyst walls intact (see Dale, 1979). A separate procedure useful for cysts of *Chattonella* and other species is also given below.

Sieving technique (non-quantitative)

1. Prepare a series of sieves of various mesh-sizes. These can either be commercially available metal sieves employed in sediment grain size analysis, or hand-made, inexpensive units (short, open segments of PVC pipe with Nitex mesh epoxied to one end). Useful sizes are 250, 125, 80, 38, and 20 µm. Choose a suitable series of sieves for the sediments being processed and the species of interest. For example, a 250 µm sieve is not needed unless sediments contain many broken pieces of shell or plant tissue. For cysts of small species (i.e. *Alexandrium* or *Scrippsiella*), a 20 µm sieve is used in the final step to collect the particles of interest; for larger species, a 38 µm sieve is used. Usually, only two sieves are needed, one to remove large debris and the smaller to collect the particles in the size range of interest.
2. Take 5-10 mls of sediment slurry and add filtered seawater (FSW). This slurry can then be sonicated or not, depending on the objective of the study. If cyst enumeration is the only goal, sonication is recommended, as it disaggregates particles and frees cysts from other detritus. Sonication prior to physiological studies is potentially problematic, as it is not known if the ultrasound has effects on cyst physiology. When clean, detritus-free cysts are required for a study, sonication is the only alternative. In such cases, careful temperature control using a water bath during sonication is recommended to eliminate heating effects. Probe sonicators are preferable to bath-type units due to their higher energy, although the latter will work if samples are small and are left in the bath for extended periods (5-10 min, minimum). There are many different brands of sonicators, so the necessary processing time varies. Start with 30 sec to 1 min at a moderate setting with probe units. This can be adjusted depending on results.

3. The sonicated (or unsonicated) sample is then poured slowly through the largest sieve (typically 125 or 80 μm) and the filtrate collected in a beaker. The sieve is rinsed thoroughly with FSW, and all the liquid that was collected in the beaker is poured through the smallest mesh (typically 38 or 20 μm). This liquid will go through more slowly than with the larger mesh, but flow can be increased by tapping the sieve with your fingers from below, blotting on paper towels, or by spraying with FSW. The material on the sieve is then washed into another beaker, Petri dish, or vial. The final dilution of sediment into the vial with the FSW should be light-gray in color. Five to 10 mls of slurry optimally gives about 10 mls of suspension for analysis.
4. There are several methods for separating the cysts from heavier materials. One is to put the final suspension in a small beaker (25-50 ml) and to move the beaker in continuous small circles on the bench top. This creates a vortex in the sample, which collects sand in the center and keeps cysts and lighter material in suspension. A pipette can then be used to remove the bulk of the liquid while the swirling continues, leaving behind a residue of sand to be discarded. Alternatively, if the sample is placed in a Petri dish, FSW can be squirted at one side of the dish using a wash bottle in such a way that the residue is surrounded by the swirling motion of water. Cysts and other light particles will be suspended in the circulating water while heavy sand particles remain at the bottom in the center of the Petri-dish.

Sieving technique (quantitative)

Quantitative methods for cysts in sediment cores are detailed in Anderson *et al.* (1982a) but are summarized below for convenience. The following procedure applies to intact sediment cores.

1. Set-up a ringstand near a sink or source of running water and stabilize with duct tape, C-clamps, or a lead weight at the base. Place a bucket in the sink for the discarded sediment.
2. Place the core tube in the ringstand, remove top core cap, and then carefully remove the overlying water by aspiration. Be sure that the core is undisturbed and that any surface disturbances have settled before aspirating. Suction all the water, removing as little of the flocculent surface layer as possible.
3. Make an extrusion stopper – typically a rubber stopper that is cut horizontally so that it fits snugly inside the core tube. It should be snug enough to support the weight of the overlying sediment without sliding down the core tube, yet loose enough to allow you to push the sediment upwards from below. Place the extrusion stopper on the lab bench.
4. Remove the bottom core cap and very quickly push the bottom of the core tube onto the extrusion stopper while pushing down on the core tube. Place an extruder against the bottom of the core tube and push the sediment up until the top edge of the sediment is even with the top edge of the core tube. The extruder is any cylindrical device that is smaller than the diameter of the core tube that can be used to push the extrusion stopper upwards. A smaller diameter, but longer (capped) core tube works well.
5. Wipe any moisture off the core tube and mark, with a waterproof pen, the intervals to be sectioned. Typically the core is cut into 1 or 2 cm slices, 6-12 cm deep into the core. Start by making the first mark at a convenient and visible reference point on the core tube, usually the interface between the extruder and the bottom of the extrusion stopper. Using a metric rule, mark off the appropriate intervals up to the desired depth or until you reach the top of the core tube.
6. To subsample the first interval, which is usually very liquid, push the fluid sediment up a few millimeters. Place a beaker alongside the top edge of the core tube, then scrape the

sediment into the beaker with the large spatula. Repeat until you have reached the interval mark (i.e. 1-2 cm) as designated by lining up the interval marks on the core tube with the reference point (i.e. the extrusion stopper/extruder interface). Do not push too far at any one time or the sediment will run down the side of the core tube, losing part of the sample.

7. Using a small spatula, mix and then subsample from the sediment in the beaker. Measure the volume of the mud (usually 5 cm³) in a cut off syringe, eliminating all air pockets. The spoon end of the spatula works well to load the syringe and the flat end is used to scrape off the excess. Dispense the mud into a sample container. Rinse the syringe with FSW into the sample container and then rinse the walls of the sample container. Label the container with sample location, date, depth interval, etc.

8. Rinse the beaker, spatulas and syringe with tap water or seawater to prepare for the next interval. Push the sediment up another 1-2 cm with the extruder. The deeper the core is penetrated, the more compact the sediments become, and therefore less necessary to push the sediment up in small increments to complete the interval. Due to wall friction, the lower sediment layers become contaminated by the upper layers during the coring and extruding process. The outside edge of the sediment core should thus be trimmed and discarded (a few mm). This is best accomplished by slightly loosening the clamps on the ring stand, allowing the core tube to be rotated while cutting the outer edge of the sediment. Scrape the remaining sediment into a dry beaker and subsample as in Step No. 7.

9. Repeat Step No. 8 until all the intervals are subsampled. Again, the sequence of steps is to push the sediment up, trim and discard the outer edge, scrape the sample into a beaker, mix the contents of the beaker, and subsample using the small spatula and the syringe.

10. Be sure that all the samples contain adequate seawater so they will not dry out. Store the samples at an appropriate temperature (usually 2-4°C for temperate species) in the dark.

Cyst concentration

For both techniques mentioned above, one constraint is that sieved material predominantly consists of sediment and detritus. Unless cyst concentrations are high, enumeration and isolation are very time consuming. In addition, it is difficult to state with conviction that a given area is free of cysts since the methods and time constraints typically limit the amount of sediment actually examined to approximately 1 ml. Techniques have thus been developed to concentrate cysts from both sediments and laboratory cultures. The Percoll-seawater density gradient procedure which has been used to separate live meiofauna and microfauna from sediments is not suitable for dinoflagellate cyst concentration because the maximum density of the medium is ~ 1.15 g cm⁻³, which will not "float" all cysts. The metrizamide gradient method used by Anderson *et al.* (1985) has the correct range of densities for cysts, but is expensive for large-scale studies. A new method was thus developed for separating and concentrating cysts using a non-toxic, aqueous colloidal silica suspension called Nalco 1060 (Schwinghamer *et al.*, 1991). The procedure is summarized as follows.

1. Prepare a "light" and "dense" solution of Nalco. The light solution should be 22.46% (wt/vol) sucrose in distilled water, buffered to pH 8.1 with 0.0125 M Tris plus 0.0125 M Tris HCl (final concentration). The dense solution should be a 50% (wt/wt) suspension of colloidal silica (Nalco 1060; Nalco Chemical Co., Chicago, IL) and aqueous sucrose at a final concentration of 11.23% (wt/wt), buffered to pH 8.1 with 0.0125 M Tris plus 0.0125 M Tris HCl.

2. Prepare either linear gradients (using a gradient mixer) or a step gradient in a 50 ml centrifuge tube using the two solutions. A step gradient is formed by placing a 5 ml cyst

suspension in a 50 ml centrifuge tube. The 20 ml of light solution is carefully injected underneath the sample, thereby displacing it upwards. In the same manner, 20 ml of dense solution is pipetted beneath the light solution.

3. If a linear gradient is used, carefully *underlay* a 5 ml sediment slurry (or culture cyst suspension) below 40 ml of gradient. A pipette works well if care is taken not to disturb the layers.
4. Balance the tubes by adding or removing liquid at the surface.
5. Centrifuge at 3000 rpm (~ 1600 x g) for 30 min at 4°C.
6. With a linear gradient, withdraw centrifuged material in 5.0 ml aliquots using either the device described by Schwinghamer *et al.* (1991) or careful pipetting. One or at most two aliquots should contain a clean suspension of cysts. If a step gradient is used, cysts should be found at the interface between the light and dense solutions.

An alternative to physically concentrating cysts to facilitate detection or enumeration is to make the cysts themselves more visible so that they stand out against a background of detritus and other organisms. One approach recently developed by Yamaguchi *et al.* (1995) relies on the fluorochrome primuline, which binds to the outer wall of *A. tamarensis* cysts. When viewed with an epifluorescence microscope, the primuline-labeled cysts exhibit an intense yellow-green fluorescence under blue-light excitation. This makes it easy to find and enumerate *A. tamarensis* cysts in a sediment sample. The method also stains other dinoflagellate cysts, but the fluorescence characteristics are sometimes different. The dark walls of *Protoperidinium* cysts, for example, do not fluoresce well following primuline staining. Work is in progress to examine the applicability of this method to a variety of dinoflagellate cysts.

Palynological technique

The technique introduced here is mainly based on standard palynological processing (Matsuoka *et al.*, 1989a). It uses several dangerous chemicals and therefore should be undertaken only with adequate safety precautions.

1. Place 1-2 mls of sediment into a 15 ml polyethylene test tube (do not use glass). Centrifuge and wash with distilled water several times to remove salt.
2. Add 5% hydrochloric acid to the tube to remove calcium carbonate from calcareous nanoplankton, foraminifera and other organisms. The calcareous cyst wall and ornaments such as on *Scrippsiella* and *Ensiculifera* will also be removed at this time, but the inner organic phragma will remain.
3. Centrifuge and wash with distilled water.
4. Add 1% potassium hydroxide solution to the tube and warm to 70°C in a water bath for 3 min. At higher temperature and with longer heating, the relatively thin phragma of *Protoperidinium* and *Alexandrium* sometimes disappear.
5. Centrifuge and wash with distilled water, then add concentrated (25-30%) hydrofluoric acid to the tube to remove silicate materials such as sand, diatoms, and silicoflagellates. Warm in the water bath at 70°C for 2-3 hrs. As the hydrofluoric acid is very dangerous and toxic, this processing should be carried out in a hood with rubber or vinyl gloves. The residue solution containing hydrofluoric acid should be neutralized with calcium carbonate.

6. Centrifuge and wash with distilled water. When cellulosic materials such as plant tissue are abundant in a sample, acetylation may be useful to remove them. The acetylation procedure is as follows:
 - a. Add glacial acetic acid to the tube.
 - b. Centrifuge and wash using Erdtman's solution, which is a mixture of 9 parts acetic anhydride and one part concentrated sulfuric acid.
 - c. Warm the tube in a water bath at 70°C for 15 min.
 - d. Remove the Erdtman's solution and add glacial acetic acid again.
 - e. Centrifuge and wash with distilled water.
7. Prepare a series of sieves of various mesh-sizes with 250 µm being the upper sieve, 125 µm in the middle and 20 µm at the bottom.
8. Pour all the residue onto the upper sieve and wash it thoroughly. Cysts and other organic particles such as spores and pollen grains will pass through 250 and 125 µm sieves and accumulate on the 20 µm sieve.
9. Wash the remaining material on the 20 µm sieve into a 20 ml vial using distilled water for a final volume of 10 ml.

CYST ENUMERATION

For presence versus absence surveys, the absolute number of cysts of a target species is not as important as the fact that the species is present in a sample. Thus the objective is to scan sufficient material to make this determination, without devoting so much time that the survey becomes unrealistic. To be thorough, 3 mls or more of the final suspension should be examined in a 1 ml capacity Sedgewick Rafter slide or its equivalent before a negative finding is noted. Scanning at 100 or 160X total magnification is most efficient. If a cyst is found, this should be verified by looking for more. Any cyst identification that is unclear should not be counted and the scanning continued. A good quality microscope is very important in this process. Poor objectives or illumination, or even poor sample processing can make many copepod eggs and pollen grains look like cysts. Cysts may even need to be isolated for closer examination under higher power, since the Sedgewick Rafter slide often cannot be used with objectives above 16X magnification. Even those skilled in cyst identification will require 20-30 min to scan a 1 ml slide, therefore 1.5 hrs may be required for one sample (2 hrs if processing is included).

For quantitative studies, the objective is to obtain an accurate estimate of the cyst abundance in a sample. This often requires determination of the horizontal and vertical cyst distribution (Anderson *et al.*, 1982a). Vertical profiles of cysts within the top 6-10 cm of a core are useful in ascertaining the number of cysts that are near the oxygenated surface layer where germination is possible, as well as the total number of living cysts in a sample. Even deeper cores are sometimes used when the long-term history of cyst deposition is sought, such as in studies of species dispersal into an area (Keafer *et al.*, 1992) or of environmental changes in an area. Horizontal cyst maps are useful in delineating the population distribution in an area or in pinpointing potential seedbeds (Tyler *et al.*, 1982; White and Lewis, 1982; Anderson and Keafer, 1985). The most useful approach is an areal contour map, which smoothes out small-scale irregularities in the cyst distribution and provides a good image of the overall cyst distribution in surface sediments. To accomplish this, it is necessary to arbitrarily select a depth interval over which the cyst abundance is to be tabulated. Given that marine sediments are typically anoxic below the top cm, one approach would be to tabulate and plot only those cysts in the oxygenated surface layer. However, this ignores the majority of the living cysts at a station, and does not account for resuspension of deeper cysts by storms, fishing, or animal activity. A compromise approach is to tabulate all cysts in the top 4-6 cm of sediment (Anderson *et al.*, 1982a).

Once the core has been processed as described above, cysts can be enumerated in any counting chamber as long as it holds sufficient volume. A 1 ml Sedgewick Rafter slide is often used, but if cysts are abundant, a 0.1 ml Palmer Maloney slide might suffice. Care should be taken to mix the cyst suspension well before subsampling, and to distribute the sample evenly over the slide. The number of cysts to count will vary with the level of accuracy desired and the time available for the study. Once the number of examined cysts is known in a given volume, the abundance in the original sediment sample can be calculated knowing the volume of sediment processed. Results are usually expressed as cysts cm^{-3} or cysts ml^{-1} of sediment, but it is also possible to dry and weigh the sediment sample so that cysts g^{-1} can be determined. Originally, it was thought that compaction of sediments would make cyst counts inaccurate if normalized to volume rather than mass, but at least in the top 10 cm of sediment, these two units of measure are essentially equivalent so the simpler approach using volume units is often employed.

Most Probable Number Method

This technique was initially introduced for the quantitative analysis of cysts of *Chattonella antiqua*, *C. marina* and resting spores of *Skeletonema costatum* in sediments by Imai *et al.* (1984) under the name "extinction dilution method". The method is useful for these and other cysts that are simple in morphology and small in size, and thus difficult to detect in sediment samples. Later Erard-Le Denn (1992) adopted this technique under yet a different name for the quantitative estimation of *Alexandrium minutum* cysts. Note that numerical data obtained by this technique are not necessarily equivalent to the number of living cysts in sediments determined by sieving techniques. The MPN data give an estimate of the abundance of cysts that are capable of germinating at that time, but since some cysts might be newly-formed, and thus incapable of germination (i.e. they are immature), the MPN method would underestimate the potential seed population of that species. It is important to understand the dormancy and excystment characteristics of the species being investigated if this method is to be used. The summary of this method given by Imai *et al.* (1984) follows, with minor modifications. Additional discussion of this method is given in chapter 4 of this volume.

- 1) One gram of sediment is taken from a core or other bottom sample and sieved using 100 μm and 20 μm mesh sizes.
- 2) The fraction retained on the 20 μm sieve is then resuspended in 10 ml of FSW in order to get a base sample in which sediment density is one-tenth of the original.
- 3) The base sample is diluted with culture medium as appropriate for a desired dilution series, final volume 10 mls. Dilutions of 1:10 and 1:100 are commonly used, though other options should be considered. Five replicate test tubes are then filled with 1 ml aliquots of the base and the diluted samples, all of which are then incubated under appropriate temperature and light conditions for the species under study.
- 4) During the incubation, the appearance of vegetative cells in the tubes is checked at four day intervals under a microscope.
- 5) The number of tubes in which the vegetative cells appear are scored as positives.
- 6) The most probable number (MPN) of cysts in the sediment sample is then calculated according to the statistical table of Throndsen (1978). See also Chapter 4 of this Manual.

CYST DYNAMICS

Cysts are important during both the initiation and decline phases of blooms, so it is often desirable to study the magnitude and mechanisms of excystment and encystment. Despite the importance of such knowledge, however, it is difficult to obtain more than qualitative information about these processes. This is due to the complex ecological transformations that are occurring and the dynamic nature of the planktonic environment.

Encystment

Several approaches have been used to study the dynamics of encystment. These include the use of sediment traps, frequent observations of sediment samples, and enumeration of planozygotes in bloom populations or the relative proportions of living vs. empty cysts.

Perhaps the best estimates of the flux of cysts to the sediments during a bloom can be obtained using sediment traps (Balch *et al.*, 1983). However, there are no widely-accepted procedures or designs, and it is known that various configurations will collect different quantities of material. Furthermore, material resuspended from the bottom and collected in the trap may complicate the interpretation of sedimentation data. Quantitative analysis of sediment trap data is thus not recommended. It is, however, possible to learn a great deal at a qualitative level about the timing and relative magnitude of cyst formation as a component of phytoplankton population dynamics (Balch *et al.*, 1983). For these purposes, sediment traps need not be elaborate or expensive. A small trap consisting of a 2 liter wide-mouth polyethylene bottle attached to a line between a surface buoy and a bottom weight can be used to collect newly produced cysts. A relatively large trap consisting of three 20-liter polyethylene bottles tethered together can be used to collect cysts for toxin analysis.

Sediment sampling

In theory, it should be possible to repeatedly subsample an area to monitor the changes in cyst abundance as excystment and encystment occur through time. In practice, care must be taken to collect and process sufficient replicate cores at several different stations to account for the patchy distribution of cysts in the sediments and the patchy bloom populations in the overlying waters. Accurate positioning of the vessel is also necessary. In studies of this type, multiple cores are taken at each of several stations. These are sectioned and processed as described above, and the abundance of cysts in the surface layers carefully enumerated. Changes in the abundance of cysts of a species can then be correlated with the dynamics of the overlying motile cell bloom population. Changes in the morphology of the cysts are useful as well, since newly-formed cysts are sometimes easily distinguished from older, mature cysts (Anderson, 1980). For some species (see below), chlorophyll fluorescence can be used to distinguish new (and germinating) cysts from those that are dormant or quiescent.

Another approach is to identify life cycle stages in the plankton that are indicative of sexuality and cyst formation. For many species, gametes are not easily distinguished from asexually dividing vegetative cells, but planozygotes and newly formed cysts are distinctive. Tabulation of these different stages as a percentage of the total population of a species can provide valuable information on the timing and magnitude of cyst formation. The simplest method is to use the large size and distinctive morphology of the planozygotes as diagnostic indicators (e.g. Anderson *et al.*, 1983), but it is also possible to use cytological techniques to stain basal bodies and flagella to provide unequivocal evidence of the life-cycle stage of individual cells (Tyler *et al.*, 1982; Coats *et al.*, 1984).

Lewis *et al.* (1979) demonstrated the utility of monitoring the relative proportions of living vs. empty cysts of *Gonyaulax polyedra* in studies of the dynamics of that species. Samples were collected and processed as described above, but empty cyst walls were counted as well as living, viable cysts. As cysts were formed and deposited in surface sediments, the percentage of empty cysts decreased, providing a useful indication of the timing and magnitude of cyst formation. This approach is useful only for those species that have resistant and distinctive cyst walls. Species such as *Alexandrium*, which produce non-descript cysts, would be difficult to study in this manner since the cyst walls would be difficult to distinguish from other detritus in a sediment sample.

EXCYSTMENT

Several of the methods used for studies of encystment dynamics can also be applied to excystment studies. Frequent sampling of sediments to monitor cyst abundance and vertical distribution can sometimes reveal changes associated with excystment, though again, the patchiness of cyst accumulations makes this approach difficult. Monitoring of life cycle stage in the plankton can also be attempted, in this case the newly germinated planomeiocyte being of special interest. In dinoflagellates, planomeiocytes can be distinguished by their large size and trailing, "ski track" flagella, but such features are not always discernible without special scrutiny or cytological stains. One useful procedure is to use a viscous medium such as glycerol in FSW to immobilize living cells and to make their dual longitudinal flagella visible. This procedure is obviously difficult to apply to multiple, fresh field samples. An alternative but complex approach is to use protargol staining to highlight basal bodies as diagnostic features (Coats *et al.*, 1984).

Another useful technique that can provide information on the germination dynamics of some species involves monitoring the chlorophyll fluorescence of cysts. In *A. tamarensis*, for example, quiescent cysts show no red fluorescence when excited with blue light until they begin to alter their physiology in preparation for germination. Cysts in surface sediments can thus be examined through time using an epifluorescence microscope to document the temporal change in the proportion of the population that is synthesizing chlorophyll. Anderson and Keafer (1985) used this approach to demonstrate the rapid germination cycle of *A. tamarensis* in shallow waters, compared to the long, gradual germination process in deeper coastal waters.

LABORATORY STUDIES

ISOLATION AND GERMINATION

Laboratory studies of cyst-forming species require that cultures be established. This can either be accomplished by isolating individual vegetative cells from plankton samples, or by isolating cysts and germinating them to obtain the initial cells for cultures. Isolation procedures employ micropipettes of various types. Pasteur pipettes whose tips have been drawn out over a flame (50-100 μm diameter) are commonly used, either connected to a tube which the user sucks on to draw cells into the tip, or used alone such that capillary action draws the cells up. Another method uses capillary tubes (1 mm ID, non-heparinized) which are drawn into very fine, hollow strands over a flame and snapped off to produce a narrow tip. These are attached to thin tubing (such as that used on many nutrient autoanalyzers). The thin tubing and very fine capillary tip restrict the amount of material that is drawn into the tube with mouth suction.

A small amount (~ 0.5 ml) of the sieved cyst sample is placed onto a large counting chamber such as a Sedgewick Rafter slide. Filtered seawater is then added to 1 ml, and the cysts isolated by micropipette. If necessary, a small needle (insect pin) attached to the tip of a glass tube can be used to clear the background around a cyst on the slide.

Isolated cells or cysts are placed into culture medium suitable for the species of interest. They can be incubated in culture tubes, in the wells of tissue culture plates, in Petri dishes, or in individual slides. The 96-well tissue culture plates are useful because they can be monitored using a dissecting or an inverted microscope to determine the success of the isolations. The wells are half-filled with medium, individual cysts are isolated and deposited in the well, the cover replaced, and the entire chamber sealed with plastic tape for incubation. Plates can be easily scanned with an inverted or stereo microscope, but this does not allow cysts to be easily pinpointed for individual observation. It does, however, make it very easy to quantify cyst germination as long as the emerging cells swim or divide.

If accurate germination statistics are needed, the Palmer-Maloney slide method of Wall and Dale (1968) can be used. The cyst (or cysts - no more than 10) are isolated from a sediment

sample and placed in the center of the Palmer-Maloney chamber with a small drop of medium, and a ring of Vaseline is placed around the outer edge of the raised gray surface. A large coverslip is placed over this and pressed down so that the drop of medium becomes a flattened disc that remains in the center of the slide, not touching the edges of the well or the Vaseline. No appreciable evaporation will occur for at least one week. Individual cysts are then located and their coordinates noted using the Vernier scales found on many microscope stages. Use of the coordinates allows the user to return to each specific location to look for empty cyst walls. This becomes important when pennate diatoms and other algae overgrow the slide as contaminants. [NOTE: Palmer-Maloney slides are surprisingly expensive. One alternative is to cut one or two sheets of Parafilm to the size of a microscope slide. These are placed on the slide and a well is cut out of the center.]

Some workers use 36 mm Petri dishes as a convenient and reliable vessel for germination. Filled with 2-3 mls of medium and sealed with Parafilm or similar coverings, they do not lose medium to evaporation. The entire dish can be examined under a dissecting microscope, and cysts and vegetative cells easily recognized against the dark background. The base of the dish is sufficiently clear that examination and photography with an inverted microscope is possible as well. Once germination has occurred, cells can be isolated or left to divide for relatively long periods before transfer to larger culture vessels.

The tubes, Petri dishes, tissue culture plates, or slides are placed at a suitable growth temperature under lights, with germination expected in 2-5 days. If the original cyst processing and isolation was clean and thorough, it is possible to establish a culture directly from the swimming cells in the tissue culture wells, either through individual isolations or using many cells at once (if other algal contaminants are not present). It is generally desirable to establish true clonal cultures, so isolation of individual vegetative cells (one cell per culture tube or well) is usually necessary. Note that if multiple cells produced by a cyst germination are used to start a single culture, the result will not be clonal, in a strict sense of the word. This is because most cysts are the result of mating between male and female gametes, and the germinated cyst will produce these two genetically different mating types. A true clonal culture of a heterothallic organism should not be able to produce cysts unless it is combined with a culture of an opposite mating type.

ENCYSTMENT STUDIES

The ability to form cysts in laboratory cultures is a major asset to any research program on a particular organism. Examples for marine species are found in Watanabe *et al.* (1982), Anderson *et al.* (1984), Blackburn *et al.* (1989), and Nakamura *et al.* (1990). Unfortunately, some species that respond reasonably well to culturing do not form cysts as easily. It is thus often useful to start a culture collection of numerous isolates of the species of interest, in hopes that some of them will produce cysts in sufficient quantities for laboratory study.

In laboratory cultures, depletion of either nitrogen (nitrate or ammonium) or phosphorus will often induce sexuality (e.g. Pfister, 1975; Turpin *et al.*, 1978; Anderson *et al.*, 1984). This needs to be carefully controlled, however, since cessation of growth in batch cultures due to over-crowding or carbon limitation does not generally induce cyst formation. If f/2 medium (Guillard and Ryther, 1962) is the standard, nutrient-replete growth medium for a species, reduction of phosphorus or nitrogen levels to f/40 or f/80 will often result in limitation and sexuality leading to cyst formation (Anderson *et al.*, 1984).

A problem arises in efforts to determine encystment rates using laboratory cultures, as nutrients are exhausted so quickly in batch cultures that some cells begin the process of cyst formation, but do not complete it due to unfavorable conditions (Anderson *et al.*, 1985; Anderson and Lindquist, 1985). The low yield of cysts (10-20%) reported in such studies is deceptive, since a large percentage of the motile population can be planozygotes that presumably would have formed cysts had conditions been suitable.

Nutrient limitation has also been implicated in sexual induction in natural populations, though no direct measurements have yet proven this inference. In fact, cyst production has been

observed when external nutrients were at or above concentrations that previously supported only vegetative growth (Anderson and Morel, 1979; Anderson *et al.*, 1983). The precise set of environmental cues that stimulate encystment is not well-defined, and recent studies indicate that factors other than macronutrient availability (e.g. iron stress) may be involved (Doucette and Harrison, 1989). Furthermore, given the discovery of endogenous control of cyst germination for *A. tamarense* (Anderson and Keafer, 1987), the possibility of endogenous or "clock"-regulated sexuality must also be considered.

If organisms are heterothallic (or if their mating characteristics are unknown), crosses between cultures of different isolates are necessary. In such cases, individual cultures of the strains to be crossed are grown in reduced nutrient medium and then combined. Multiple isolates crossed with each other and self-crossed will generate a matrix of successful matings that can be used to define the mating type of each isolate (e.g. Yoshimatsu 1984). For some fastidious species, extra precautions are necessary in medium preparation. Anderson *et al.* (1984) found that cyst yield of *A. tamarense* could be increased by minimizing precipitates and chemical contaminants during medium preparation and sterilization. Although tedious and somewhat expensive, the precautions described by those authors for glassware cleaning and medium preparation are recommended for optimal growth and cyst production.

EXCYSTMENT STUDIES

A number of basic physiological characteristics should be determined for the cyst of a species of interest. With respect to excystment, these include the length of the mandatory dormancy interval, and the factors that regulate quiescence or that trigger germination for that species. These studies are easiest when cysts can be formed in culture, but when laboratory cultures are not available for certain species, it is still possible to obtain relatively "clean" cyst preparations using field populations. One approach that has been successfully used on *Gymnodinium catenatum* (Anderson *et al.*, 1988) and numerous other dinoflagellate species (unpub. data) involves collection of a mixed plankton assemblage using a plankton net, and the resuspension of that material in filtered seawater from the study site which has been enriched with f/2 levels of vitamins, metals, and EDTA. Sometimes, f/80 levels of major nutrients are added as well. The assemblage is incubated in the laboratory at the temperature of the ambient water at an appropriate daylength and light intensity. Within a few days, cysts will be produced by many of the species in the sample. These are of a known age, and can readily be isolated by micropipette to study morphology or germination characteristics.

Cysts of a known age can also be collected in a sediment trap (deployed underneath a bloom but sufficiently far above the bottom to avoid resuspension of "old" cysts). The least attractive option, but one which will work if a recent bloom has produced abundant new cysts, is to collect and work with surface sediments directly. Cysts can be isolated individually for germination trials, or an alternative procedure can be attempted that utilizes unprocessed sediment. This involves the preparation of a large sample of sediment "slurry" in FSW, which is then subdivided into numerous subsamples. The cysts of interest in 5-10 of these aliquots are enumerated to obtain a statistically sound estimate of initial concentrations. The remainder of the subsamples are then incubated experimentally. The difference between the initial counts and the number of cysts remaining after incubation provides a good measure of germination success (Anderson *et al.*, 1987).

Once cyst suspensions are obtained using one of the above methods, a variety of experimental manipulations are possible. Determination of the mandatory dormancy interval for cysts or spores requires that cysts of known age be stored under different temperatures and periodically exposed to optimal growth conditions to assess germination success (Anderson, 1980; Binder and Anderson, 1987; Blackburn *et al.*, 1989). The permissive temperature "window" for germination (e.g. Anderson *et al.*, 1985) can be determined by incubating quiescent cysts across a range of temperatures (in the light) and assessing the percentage of germination after an arbitrary interval. Since germination will be slow at low temperatures, a month or more of incubation is sometimes needed. Different temperatures can be provided by

the use of multiple incubators, or through the use of a temperature gradient bar (Watras *et al.*, 1982) which is heated at one end and cooled at the other, resulting in a continuous gradient in temperature. Light requirements for germination require special handling of the cyst suspensions, as even brief exposure to low levels of light can trigger excystment in some species (Binder and Anderson, 1986). Samples can be processed in near darkness, or using a red, photographic light, though in both cases, some exposure is unavoidable. Tubes can then be wrapped with different layers of screening or shaded with neutral density filters to provide the needed light variation (Anderson *et al.*, 1987).

REFERENCES

- ANDERSON, D.M. (1980). Effects of temperature conditioning on development and germination of *Gonyaulax tamarensis* (Dinophyceae) hypnozygotes. *J. Phycol.* **16**, 166-172.
- ANDERSON, D.M.; AUBREY, D.G.; TYLER, M.A.; COATS, D.W. (1982a). Vertical and horizontal distributions of dinoflagellate cyst in sediments. *Limnol. Oceanogr.* **27**, 757-765.
- ANDERSON, D.M.; CHISHOLM, S.W.; WATRAS, C.J. (1983). The importance of life cycle events in the population dynamics of *Gonyaulax tamarensis*. *Mar. Biol.* **76**, 179-190.
- ANDERSON, D.M.; JACOBSON, D.M.; BRAVO, I.; WRENN, J.H. (1988). The unique microreticulate cyst of the naked dinoflagellate *Gymnodinium catenatum*. *J. Phycol.* **24**, 255-262.
- ANDERSON, D.M.; KEAFER, B.A. (1985). Dinoflagellate cyst dynamics in coastal and estuarine waters, pp. 219-224. In: D.M. Anderson, A.W. White and D.G. Baden (eds.), *Toxic Dinoflagellates*. Proc. 3rd Int. Conf., Elsevier, New York.
- ANDERSON, D.M.; KEAFER, B.A. (1987). An endogenous annual clock in the toxic marine dinoflagellate *Gonyaulax tamarensis*. *Nature* **325**, 616-617.
- ANDERSON, D.M.; KULIS, D.M.; BINDER, B.J. (1984). Sexuality and cyst formation in the dinoflagellate *Gonyaulax tamarensis*: Cyst yield in batch cultures. *J. Phycol.* **20**, 418-425.
- ANDERSON, D.M., KULIS, D.M., ORPHANOS, J.A., CEURVELS, A.R. (1982b). Distribution of the toxic red tide dinoflagellate *Gonyaulax tamarensis* in the southern New England region. *Est. Coast. Shelf Sci.* **14**, 447-458.
- ANDERSON, D.M.; LINDQUIST, N.L. (1985). Time-course measurements of phosphorus depletion and cyst formation in the dinoflagellate *Gonyaulax tamarensis* Lebour. *J. Exp. Mar. Biol. Ecol.* **86**, 1-13.
- ANDERSON, D.M.; LIVELY, J.S.; REARDON, E.M.; PRICE, C.A. (1985). Sinking characteristics of dinoflagellate cysts. *Limnol. Oceanogr.* **30**, 1000-1009.
- ANDERSON, D.M.; MOREL, F.M.M. (1979). The seeding of two red tide blooms by the germination of benthic *Gonyaulax tamarensis* hypnocysts. *Est. Coast. Mar. Sci.* **8**, 279-93.
- ANDERSON, D.M.; STOLZENBACH, K.D. (1985). Selective retention of two dinoflagellates in a well-mixed estuarine embayment: The importance of diel vertical migration and surface avoidance. *Mar. Ecol. Progr. Ser.* **25**, 39-50.
- ANDERSON, D.M.; TAYLOR, C.D.; ARMBRUST, E.V. (1987). The effects of darkness and anaerobiosis on dinoflagellate cyst germination. *Limnol. Oceanogr.* **32**, 340-351.
- ANDERSON, D.M., WALL, D. (1978). The potential importance of benthic cysts of *Gonyaulax tamarensis* and *Gonyaulax excavata* in initiating toxic dinoflagellate blooms. *J. Phycol.* **14**, 224-234.
- BALCH, W.M.; REID, P.C.; SURREY-GENT, S. (1983). Spatial and temporal variability of dinoflagellate cyst abundance in a tidal estuary. *Can. J. Fish. Aquat. Sci.* **40**, 244-261.

- BAXTER, M.S.; FARMER, J.G.; McKINLEY, I.G.; SWAN, D.S.; JACK, W. (1981). Evidence of the unsuitability of gravity coring for collecting sediment in pollution and sedimentation rate studies. *Environ. Sci. Tech.* **15**, 843-846.
- BINDER, B.J.; ANDERSON, D.M. (1986). Green light-mediated photomorphogenesis in a dinoflagellate resting cyst. *Nature* **322**, 659-661.
- BINDER, B.J.; ANDERSON, D.M. (1987). Physiological and environmental control of germination in *Scrippsiella trochoidea* (Dinophyceae) resting cysts. *J. Phycol.* **23**, 99-107.
- BLACKBURN, S.I.; HALLEGRAEFF, G.M.; BOLCH, C.J. (1989). Vegetative reproduction and sexual life cycle of the toxic dinoflagellate *Gymnodinium catenatum* from Tasmania, Australia. *J. Phycol.* **25**, 577-590.
- BOLCH, C.J., BLACKBURN, S.I., CANNON, J.A., HALLEGRAEFF, G.M. (1991). The resting cyst of the red tide dinoflagellate *Alexandrium minutum* (Dinophyceae). *Phycologia* **30**, 215-219.
- CEMBELLA, A.D.; TURGEON, J.; THERRIAULT, J.C.; BELAND, P. (1988). Spatial distribution of *Protogonyaulax tamarensis* resting cysts in nearshore sediments along the north coast of the lower St. Lawrence estuary. *J. Shellfish Res.* **7**, 597-610.
- COATS, D.W.; TYLER, M.A.; ANDERSON, D.M. (1984). Sexual processes in the life cycle of the bloom-forming dinoflagellate *Gyrodinium uncatenum*: a morphogenetic overview. *J. Phycol.* **20**, 351-361.
- DALE, B. (1977). Cysts of the toxic red-tide dinoflagellate *Gonyaulax excavata* Balech from Oslofjorden, Norway. *Sarsia* **63**, 29-34.
- DALE, B. (1979). Collection, preparation, and identification of dinoflagellate resting cysts. In: D.L. Taylor and H.H. Seliger (eds.), *Toxic Dinoflagellate Blooms*, pp. 443-452. Proc. 2nd Int. Conf. Elsevier/North Holland.
- DALE, B. (1983). Dinoflagellate resting cysts: "benthic plankton". In: G.A. Fryxell (ed.), *Survival Strategies of the Algae*, pp. 69-136. Cambridge Univ. Press, Cambridge.
- DOUCETTE, G.J.; HARRISON, P.J. (1989). Cyst formation in the red tide dinoflagellate *Alexandrium tamarensis* (Dinophyceae): effects of iron stress. *J. Phycol.* **25**, 721-731.
- ERARD-LE DENN, E. (1991) Recent occurrence of red tide dinoflagellate *Alexandrium minutum* Halim from the northwestern coasts of France. In: J.S. Park, and H.K. Kim (eds.) *Recent approaches on red tides*, p. 85-98, National Fisheries Research and Development Agency, Korea.
- FUKUYO, Y. (1982). Cysts of naked dinoflagellates. pp. 205-214. In: *Fundamental Studies of the effect of marine environment on the outbreaks of red tides*. Reports of Environmental Sciences, B 148-R14-8, Monbusho, Tokyo.
- FUKUYO, Y.; TAKANO, H.; CHIHARA, M.; MATSUOKA, K. (1990). *Red Tide Organisms in Japan.*, pp. 88-89. Uchida Rokakuho, Tokyo.
- GUILLARD, R.R.L.; RYTHER, J.H. (1962). Studies of marine planktonic diatoms. I. *Cyclotella nana* Hustedt and *Detonula confervacea* (Cleve). *Gran. Can. J. Microbiol.* **8**, 229-239.
- HUBER, G.; NIPKOW, F. (1922). Experimentelle Untersuchungen über Entwicklung von *Ceratium hirundinella* O.F.M. *Zeitscher. Botanik* **14**, 337-371.
- HUBER, G.; NIPKOW, F. (1923). Experimentelle Untersuchungen über Entwicklung und Formbildung von *Ceratium hirundinella* O.Fr. Mull. *Flora*, New Series **116**, 114-215.
- KEAFER, B.A.; BUESSELER, K.O.; ANDERSON, D.M. (1992). Burial of living dinoflagellate cysts in estuarine and nearshore sediments. *Mar. Micropaleont.* **20**, 147-161.
- IMAI, I.; ITOH, K.; ANRAKU, M. 1984 Extinction dilution method for enumeration of dormant cells of red tide organisms in marine sediments. *Bull. Plankton Soc. Japan*, **31**, 123-124.
- IMAI, I., ITOH, K. (1988). Cysts of *Chattonella antiqua* and *C. marina* (Raphidophyceae) in sediments of the Inland Sea of Japan. *Bul. Plank. Soc. Japan.* **35**, 35-44.

- IMAI, I., ITAKURA, S. (1991) Densities of dormant cells of the red tide flagellate *Heterosigma akashiwo* (Raphidophyceae) in bottom sediments of northern Hiroshima Bay, Japan. *Bull. Jap. Soc. Microb. Ecol.*, **6**: 1-7.
- IMAI, I., ITAKURA, S., ITOH, K. (1991). Life cycle strategies of the red tide causing flagellates *Chattonella* (Raphidophyceae) in the Seto Inland Sea. *Mar. Pol. Bul.* **23**, 165-170.
- KEAFER, B.A., BUESSELER, K.O., ANDERSON, D.M. (1992). Burial of living dinoflagellate cysts in estuarine and nearshore sediments. *Mar. Micropaleont.* **20**, 147-161.
- LEWIS, C.M.; YENTSCH, C.M.; DALE, B. (1979). Distribution of *Gonyaulax excavata* resting cysts in the sediments of Gulf of Maine. In: D.L. Taylor and H. H. Seliger (eds.), *Toxic Dinoflagellate Blooms*, pp. 235-238. Elsevier/North Holland, N.Y.
- MATSUOKA, K. (1985a). Organic-walled dinoflagellate cysts from surface sediment of Nagasaki Bay and Senzaki Bay, West Japan. *Bul. Fac. Liberal Arts, Nagasaki Univ. Natural Science* **25**, 21-115.
- MATSUOKA, K. (1985b) Archeopyle structure in modern *Gymnodiniales* dinoflagellate cysts. *Rev. Palaeobot. and Palyn.* **44**, 217-231.
- MATSUOKA, K.; FUKUYO, Y.; ANDERSON, D.M. (1989a). Methods for modern dinoflagellate cyst studies. pp. 461-480, In: T. Okaichi, D.M. Anderson, and T. Nemoto (eds.), *Red Tides: Biology, Environmental Science, and Toxicology*, Elsevier, New York.
- MATSUOKA, K. (1987). Organic-walled dinoflagellate cysts from surface sediments of Akkeshi Bay and Lake Saroma, North Japan. *Bul. Fac. Liberal Arts, Nagasaki Univ. Natural Science* **28**:35-123.
- MATSUOKA, K., FUKUYO, Y., GONZALES, C.L. (1989b). A new discovery of cysts of *Pyrodinium bahamense* var. *compressum* from the Samar Sea, Phillipines. pp. 301-304. In: T. Okaichi, D.M., Anderson, and T. Nemoto (eds.), *Red Tides: Biology Environmental Science and Toxicology*. Elsevier, N.Y.
- NAKAMURA, N.; UMEMORI, T., WATANABE, M.; KULIS; ANDERSON, D.M. (1990). Encystment of *Chattonella antiqua* in laboratory cultures. *J. Oceanogr. Soc. Japan.* **46**, 35-43.
- PFIESTER, L.A. (1975). Sexual reproduction of *Peridinium cinctum* f. *ovoplanum* (Dinophyceae). *J. Phycol.* **11**, 259-265.
- PFIESTER, L.A. (1977). Sexual reproduction of *Peridinium gatunense* (Dinophyceae). *J. Phycol.* **13**, 92-95.
- PFIESTER, L.A.; ANDERSON, D.M. (1987). Dinoflagellate life cycles and their environmental control. In: F.J.R. Taylor (ed.), *The Biology of Dinoflagellates*, pp. 611-648. Blackwell Scientific Publications, Ltd.
- SCHWINGHAMER, P.; ANDERSON, D.M.; KULIS, D.M. (1991). Separation and concentration of living dinoflagellate resting cysts from marine sediments via density-gradient centrifugation. *Limnol. Oceanogr.* **36**, 588-592.
- STEIDINGER, K.A., TESTER, L.S., TAYLOR, F.J.R. (1980). A redescription of *Pyrodinium bahamense* var. *compressa* (Bohm) stat. nov. from Pacific red tides. *Phycologia* **19**, 329-337.
- THRONDSSEN, J. (1978). The dilution-culture method, pp. 218-224. In: A. Sournia (ed.), *Phytoplankton Manual*, Unesco, Paris.
- TURGEON, J.; CEMBELLA, A.D.; THERRIAULT, J.-C.; BELAND, P. (1990). Spatial distribution of resting cysts of *Alexandrium* spp. in sediments of the lower St. Lawrence estuary and the Gaspé coast (Eastern Canada). In: E. Graneli, B. Sundstrom, L. Edler, and D.M. Anderson (eds.), *Toxic Marine Phytoplankton*, pp. 238-243, Elsevier, New York.
- TURPIN, D.H.; DOBEL, P.E.R.; TAYLOR, F.J.R. (1978). Sexuality and cyst formation in Pacific strains of the toxic dinoflagellate *Gonyaulax tamarensis*. *J. Phycol.* **14**, 235-238.

- TYLER, M.A.; COATS, D.W.; ANDERSON, D.M. (1982). Encystment in a dynamic environment: deposition of dinoflagellate cysts by a frontal convergence. *Mar. Ecol. Prog. Ser.* **7**, 163-178.
- VON STOSCH, H.A. (1973). Observation on vegetative reproduction and sexual life cycles of two freshwater dinoflagellates, *Gymnodinium pseudopalustre* and *Woloszynskia apiculata* sp. nov. *Br. Phycol. J.* **8**, 105-134.
- WALKER, L.M.; STEIDINGER, K. A. (1979). Sexual reproduction in the toxic dinoflagellate *Gonyaulax monilata*. *J. Phycol.*, **15**, 312-315.
- WALL, D. (1971). Biological problems concerning fossilizable dinoflagellates. *Geoscience and Man*. III: 1-15.
- WALL, D.; DALE, B. (1968). Modern dinoflagellate cysts and evolution of the Peridiniales. *Micropaleontology* **14**, 265-304.
- WATANABE, M.M.; WATANABE, M.; FUKUYO, Y. (1982). Encystment and excystment of red tide flagellates. I. Induction of encystment of *Scrippsiella trochoidea*. Nat. (Japan) Inst. Environ. Stud., Res. Rep. No. 30: *Eutrophication and Red Tides in the Coastal Marine Environment*. Pp. 27-42.
- WATRAS, C.J.; CHISHOLM, S.W.; ANDERSON, D.M. (1982). Regulation of growth in an estuarine clone of *Gonyaulax tamarensis*: Salinity-dependent temperature responses. *J. Exp. Mar. Biol. Ecol.* **62**, 25-37.
- WHITE, A.W.; LEWIS, C.M. (1982). Resting cysts of the toxic, red tide dinoflagellate *Gonyaulax excavata* in Bay of Fundy sediments. *Can. J. Fish. Aquat. Sci.* **39**, 1185-1194.
- YAMAGUCHI, M.; ITAKURA, S.; IMAI, I.; ISHIDA, Y. (1995). A rapid and precise technique for enumeration of resting cysts of *Alexandrium* spp. (Dinophyceae) in natural sediments. *Phycologia*. **34**, 207-214.
- YOSHIMATSU, S. (1981). Sexual reproduction of *Protogonyaulax catenella* in culture I. Heterothallism. *Bull. Plankton Soc. Japan* **28**, 131-139.
- YOSHIMATSU, S. (1984). Sexual reproduction of *Protogonyaulax catenella* in culture. II. Determination of mating type. *Bull. Plankton Soc. Japan* **31**, 107-111.